

## FAN-42

### EXTRACTION FAN

The FAN-42 is a wall-mounted extraction fan that provides extraction for T-Flex/CW, Flex and UltraFlex extraction arms:

- being part of a central filter system; or
  - connected to a 2 or 4 m extension crane (with or without filtration).
- The FAN-42 can be mounted directly to the wall.

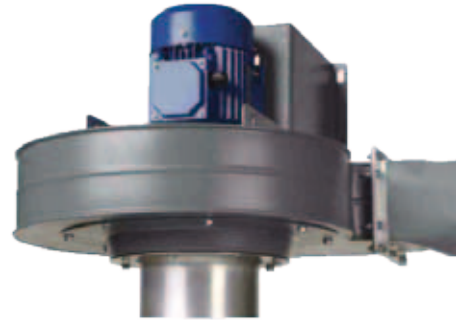

#### APPLICATIONS

The FAN-42 is intended to be used for the following applications:

- MIG-MAG/GMAW welding
- TIG welding
- FCAW welding
- stick/MMAW welding



Do **not** use the FAN-42 for the following applications or in the following circumstances:

- arc-air gouging
- aluminium laser cutting
- extraction of aggressive fumes and gases (e.g. from acids, from alkaline, from soldering paste containing lithium)
- extraction of hot gases (more than 45°C/113°F continuously)
- grinding aluminum and magnesium
- flame spraying
- extraction of cement, saw dust, wood dust etc.
- sucking cigarettes, cigars, oiled tissues and other burning particles, objects and acids
- explosive environments or explosive substances/gases



#### SPECIFICATIONS

##### Physical dimensions and properties

Material	steel
Colour:	
• Housing	• grey
• Motor	• blue
Inlet diameter	Ø 200 mm (Ø 7.87 in.)
Outlet diameter	Ø 160 mm (Ø 6.30 in.)
Weight (net)	44 kg (97 lbs.)

##### Performance

Fan type	radial
Unrestricted airflow	3000 m³/h
Speed	2800 rpm
Sense of rotation	• RD type: clockwise • LG type: counterclockwise
Noise level	72 dB(A) according to ISO 3746

##### Electrical data

Power consumption	1,5 kW (2 HP)
-------------------	---------------

Available connection voltages	230V/3~/50Hz; 400V/3~/50Hz; 120V/1~/60Hz;
Max. start/stops per hour	30
Insulation class	F
Protection class	IP 55

##### Ambient conditions

Operating temperature:	
• Min.	• 5°C (41°F)
• Nom.	• 20°C (68°F)
• Max.	• 45°C (113°F)
Max. relative humidity	80%
Outdoor use allowed	no
Storage conditions	• 5-45°C (41-113°F) • relative humidity max. 80%

##### Product combinations

T-Flex/CW	telescopic extraction arm
Flex-3/4 (+ NEC-2/4)	flexible extraction arm (+ extension crane)
UltraFlex-3/4 (+ NEC-2/4)	ultraflexible extraction arm (+ extension crane)

##### Available options

Motor protection switch:	FAN-42:
• MPS 4.0-6.3 A	• 230V/3~/50Hz
• MPS 2.5-4.0 A	• 400V/3~/50Hz
Thermal relay:	FAN-42:
• NTR 4.0-6.3 A	• 230V/3~/50Hz
• NTR 3.0-4.7 A	• 400V/3~/50Hz

##### Scope of supply



Extraction fan incl. inlet and outlet flange - Flexible hose 1,5 m Ø 200 mm - Connection flange Ø 160-200 mm - Bush (2) - Hose clamp (2) - Hardware

##### Order information

Article numbers:	
• 7906010050	• FAN-42 RD 230V/3~/50Hz
• 7906010010	• FAN-42 RD 400V/3~/50Hz
• 7906010020	• FAN-42 RD 120V/1~/60Hz
• 7906020050	• FAN-42 LG 230V/3~/50Hz
• 7906020010	• FAN-42 LG 400V/3~/50Hz
Number/package	1

■ Shipping data	
Gross weight	
Packing dimensions	
Max. number/pallet	2
Harmonized Tariff Code	8414.5940.90
Country of origin	the Netherlands

#### APPROVALS/CERTIFICATES

	
	Directive 2011/65/EC (RoHS) valid as of 8 June 2011

#### DIMENSIONS

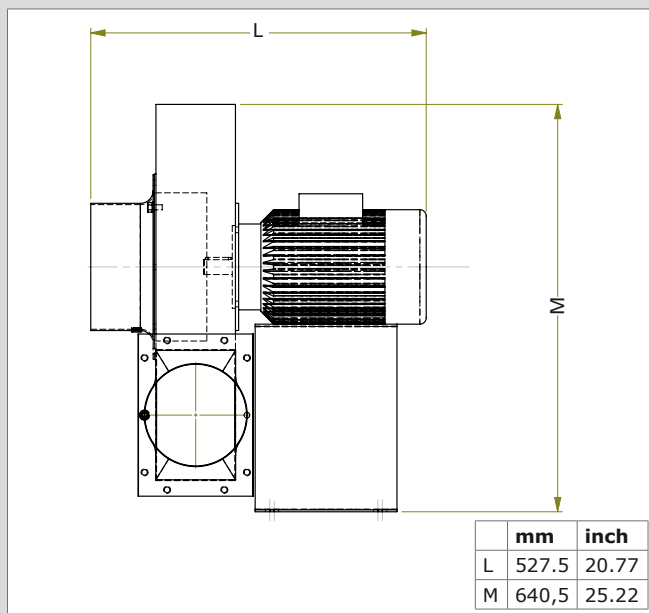
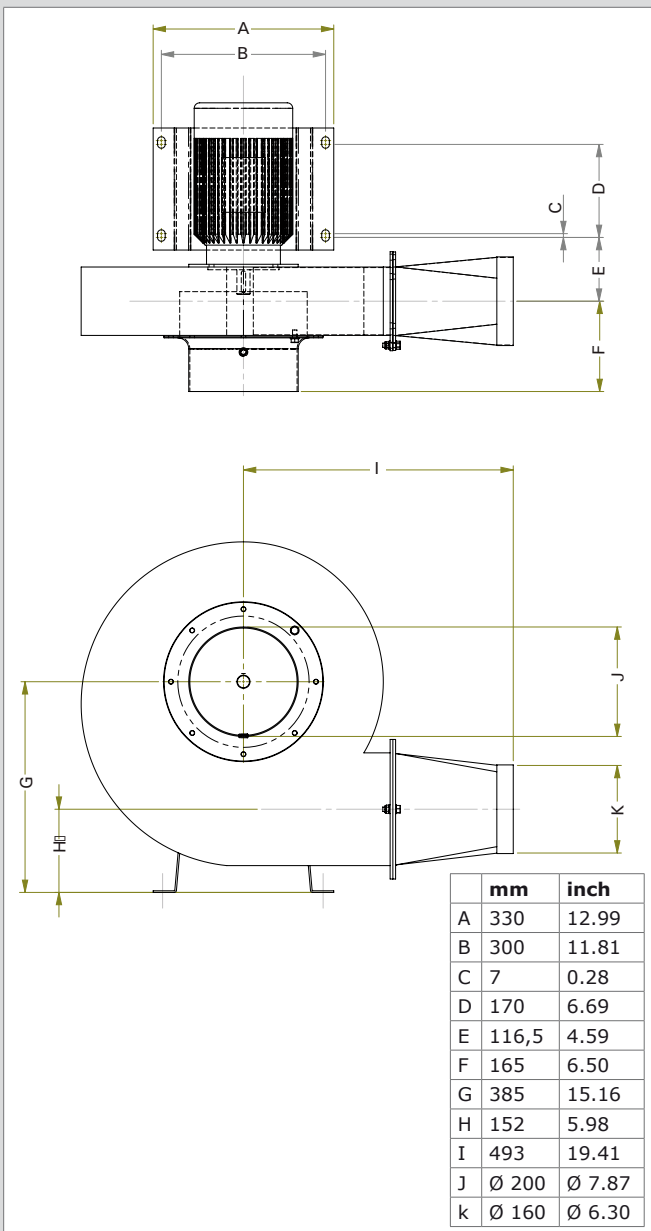

#### FAN CURVE

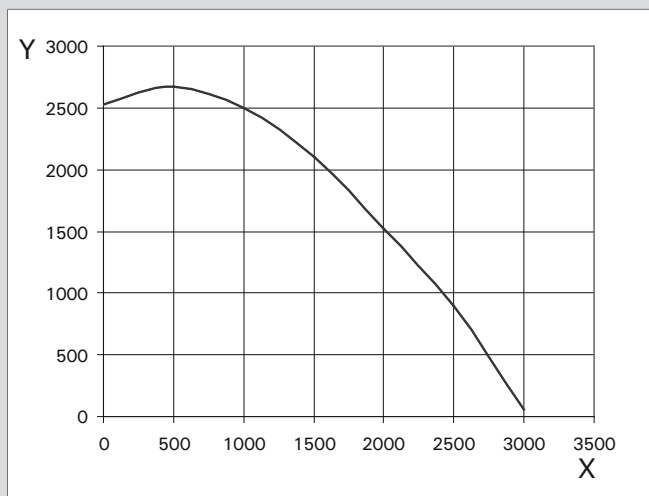

Product type

**FAN-42**

Article no.

refer to order information

Product category

extraction fans

Version

080212/D

Always check the latest version on [www.plymovent.com](http://www.plymovent.com).