

## MOBILE FILTER UNITS



A flexible solution for source  
extraction of welding fumes



## DO YOU REMOVE WELDING FUMES EFFECTIVELY?

**We do.** Removing welding fumes in a welding workshop, especially at the source, contributes significantly to a better work environment. Source extraction remains the most effective method of capturing and removing welding fumes directly from the breathing zone of the welder.

For more than 35 years, Plymovent has been specialising in the extraction and filtration of welding fumes. We offer high-quality solutions that keep the background concentration of welding fumes within the legal limits, in accordance with international guidelines.

All our extraction and filtration products are designed primarily to remove and control welding fumes in the metal-working industry to protect the welders and people working nearby. The result: better work performance, increased productivity and less absence due to illness.

## FLEXIBLE SOLUTION

Plymovent's mobile filter units are designed to remove welding fumes on-site in confined spaces and spaces that are difficult to reach by fixed welding fume extraction systems, for example in the middle of a workshop or reversely, in an outer corner of a facility. Each mobile unit has four wheels of which two swivel casters, to facilitate easy movement.

The units are suitable for both steel and stainless steel<sup>1</sup> welding applications, such as MIG, MAG, TIG, GMAW, FCAW and stick electrode welding.

## VARIOUS MODELS

Plymovent offers three models, each with its own benefits and unique characteristics. All filter units contain an aluminium spark arrester to remove sparks safely and quickly. Depending on your requirements, you can choose a model for light-to-moderate or intensive usage.



MFD with a disposable filter



MFS with a self-cleaning system



MFE with an electrostatic filter

<sup>1</sup> applies to the IFAW3 certified MFD unit.

## MFD MECHANICAL FILTER

The MFD unit is based on the mechanical DuraFilter system<sup>2</sup>. This system contains a square disposable filter cartridge with a filter surface of 50 m<sup>2</sup>. The MFD unit is very user-friendly, as the clogged filter indicator shows whether extraction is still fully satisfactory or whether the filter needs to be replaced. The filter is precoated. The coating materials used extend its lifespan. Furthermore, precoating increases efficiency, as the SurfacePlus coating intercepts dust and fume particles at an early stage.

As the MFD unit contains a paper filter, it is particularly suited for dry or 'virtually' dry welding fume activities. It is recommended for light-to-moderate welding activities.

<sup>2</sup> DuraFilter system: the special construction (pleats) and the embossing of the filter medium guarantee an equal airflow over the filter. The cartridge is built of cellulose fibres and shaped into a square profile. It is also provided with cardboard corners. As a result, the pollution is divided equally over the entire filter surface.

## MFS SELF-CLEANING FILTER

The MFS filter is fitted with RoboClean. This self-cleaning system cleans the filter cartridge automatically, section wise, through compressed air during operation hours. Dust and particles fall into the dust tray underneath. The MFS unit's maintenance-friendly DuraFilter has a filter surface of 30 m<sup>2</sup>. The filter is precoated. The coating materials used extend its lifespan. Furthermore, precoating increases efficiency, as the SurfacePlus coating intercepts dust and fume particles at an early stage.

The MFS has been developed especially for intensive welding activities with dry welding fumes. It is equipped with an external connection as standard, to supply the compressed air.

The **MFS-C** version contains a built-in compressor to optimise flexibility.



## FEATURES

### MOBILE FILTER UNITS

- Flexible; facilitate easy movement.
- Functional, mobile design.
- Effective extraction at the source.
- Low noise level.
- User and maintenance-friendly.
- Compact unit, including integrated fan.
- Integrated spark arrester.

### CODE COMPLIANT

The MFD mobile filter unit is IFA W3 certified according to the European standard DIN EN ISO 15012-1 (2005). Welding fume class W3 confirms that the certified MFD mobile filter unit is recommended for the separation of particles generated by welding of high-alloyed steel with a nickel and chromium content > 30%.



## EXTRACTION ARMS AND HOSES

Naturally Plymovent's extraction arms and hoses can be attached to the MFD, MFS and MFE mobile filter units to reach the required length. Below is an overview of the reach of a unit including an extraction arm, for the Flex/UltraFlex-3 and Flex/UltraFlex-4 respectively.

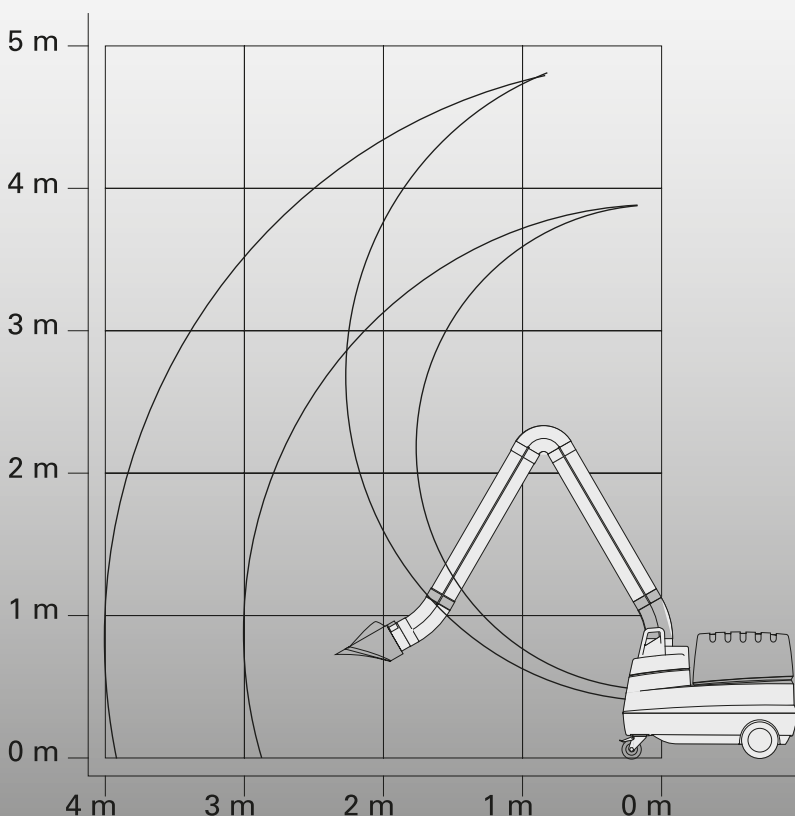

## FLEX-3/FLEX-4

Both extraction arms, Flex-3 and Flex-4, can be placed on top of a unit. The Flex-3 extraction arm is 3 metres in length and Flex-4 is 4 metres.

## ULTRAFLEX-3/ULTRAFLEX-4

In addition to Flex arms, we also supply UltraFlex extraction arms, which are developed especially for easy repositioning. The UltraFlex arms are more flexible and lighter. These extraction arms can be provided with a working light and automatic start/stop device if required.

## SUS-5/203

This flexible extraction hose is developed especially for these mobile filter units. Each hose is 5 m (203 mm diameter). The hose is equipped as standard with a suction nozzle, and fitted with a magnetic foot. This is used to situate the welding fume extractor close to the welding source.



## PLYMOVENT OFFERS TOTAL SOLUTIONS FOR AIR CLEANING

In addition to mobile plug & play filter units, Plymovent also offers extraction arms, downdraft tables, extraction hoods, portable and stationary filter units, fans and general ventilation and filtration systems to remove welding fumes in the metalworking industry.

We not only have extensive knowledge of the extraction and filtration of welding fumes in metalworking industries, but we are also specialised in the removal of vehicle exhaust fumes, oil mist, tobacco smoke and other indoor air pollution.

Contact us to find out what genuine commitment to customer requirements really means.

## MFE ELECTROSTATIC FILTER

The MFE unit has an electrostatic filter cell, whereas the MFD and MFS both have paper filter cartridges. The electrostatic filter cell consists of two separate sections: ionizer and collector. Therefore, the MFE is highly recommended for oily welding applications.

The aluminium filter cell is easy to clean and does not need to be replaced. The open filter structure ensures a constant suction level. The convenient sliding system ensures that maintenance can be carried out quickly. Regular maintenance/cleaning will ensure effective filtration and keep the unit working efficiently.

## MOBILE FILTER UNITS IN A NUTSHELL

### MFD

- 'Virtually' dry welding fumes
- Light-to-moderate welding activities

### MFS

- Dry welding fumes
- Intensive usage

### MFE

- Welding activities that include oil treated steel

## EXTRA OPTIONS

The MFD and MFE units can be extended with an activated carbon filter to adsorb unpleasant smells and penetrating odours.



# PLYMOVENT®

clean air at work

International Sales  
Plymovent Group BV  
P.O. Box 1045  
1700 BA Heerhugowaard  
The Netherlands

T +31 (0)72 5640 604  
F +31 (0)72 5644 469  
E [export@plymovent.com](mailto:export@plymovent.com)

## FROM SCRATCH TO THE RIGHT SOLUTION

Plymovent is not just a manufacturer. We offer professional advice and engineering services to provide a solution tailored to your specific needs or requirements. In addition, we offer service and maintenance services to keep your system functioning optimally. For more information, please contact your authorised Plymovent distributor or visit our website.

Your authorised Plymovent distributor:

*Plymovent cares about the air you breathe. We offer products, systems and services which ensure clean air at work, anywhere in the world.*

*We respect the environment and we deliver high-quality products. Our expertise gained over many years and our genuine commitment to customer requirements enable us to provide precisely the solutions you need.*